

CHOOSING AND USING THE RIGHT SCREW

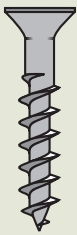

Traditional — The shape and design of the traditional wood screw has changed little over time. Some new versions use a Phillips drive. Although they require you to drill separate pilot and shank holes, many woodworkers still use the traditional screws in antique or reproduction pieces that call for matching hardware.

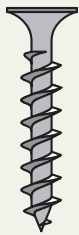

Drywall, Deck — These resemble production screws except for their bugle heads. Drywall screws have a black-oxide coating and often employ a double-lead thread. Drywall screws lack the strength of production screws.



Production — Originally designed for use in furniture factories and cabinet shops, these screws work well in solid wood and also provide excellent holding power in plywood, particle board, and medium-density fiberboard. The sharp threads help to prevent the wood from splitting, and the hardened steel shanks reduce breakage.

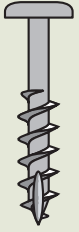

Pocket Hole — Combining a pan-style head with an auger-point tip on a production-style screw shaft yields a pocket-hole screw. The auger point helps prevent splitting when driving these screws into end grain. The flat bottom of the pan head helps to clamp the workpieces together by seating the screw tightly in the pocket hole.

PRODUCTION SCREWS

(Actual Sizes)

Gauge		4	6	8	10	12	14
Head Bore Size							
		7/32"	17/64"	11/32"	23/64"	7/16"	1/2"
Shank-Hole/ Pilot-Hole Size	Hardwood	5/64"	7/64"	1/8"	9/64"	5/32"	3/16"
	Softwood	1/16"	3/32"	7/64"	1/8"	9/64"	5/32"
Phillips-Head Point Size		#1		#2			#3
Square-Drive Bit Size		#0	#1	#2			#3

SQUARE DRIVER BIT COLOR CODE

Screw Size	Driver Size	Color Code	Screw Size	Driver Size	Color Code
#4	#0 Bit	Light Yellow	#8, 9, 10	#2 Bit	Red
#5, 6, 7	#1 Bit	Medium Green	#12, 14	#3 Bit	Black

HEAD TYPES



Flat — The most common type of screw head. Used for general fastening. Requires a countersink in workpiece.



Trim — Narrow-diameter head looks and acts like a finish nail. Eliminates the need for a countersink and counterbore.



Oval — Head projects above surface of workpiece for a decorative effect. Prevents rough edges that occur when a flathead screw does not countersink perfectly flush.



Bugle — Tapered head snugs screw into the workpiece without requiring a countersink. Found on drywall and deck screws.

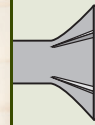

Self-Sinking — Nibs on the underside of the head cut the wood to create a countersink as the screw is driven. Use when the head will sit flush with the workpiece.



Round — Flat bearing surface under head distributes load evenly when attaching metal to wood. Some decorative uses.

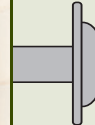

Round Washer — Built-in washer under head distributes load over a wide area and helps hold soft, thin, or brittle material.

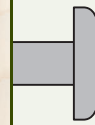

Pan/Truss — Large, flat head allows some latitude in positioning hardware such as hinges and drawer slides. Also found on pocket-hole screws.

SCREW DIMENSIONS

We have listed screw dimensions in two forms — a table showing the maximum and minimum decimal dimensions (right) and a table showing the maximum fractional dimensions (lower right). Note that the fractional dimensions are the best approximations of the actual decimal dimensions.

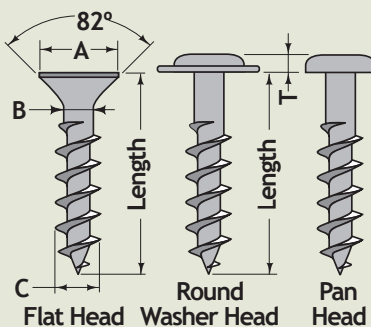

Size	"A" Flat Head		"A" Pan Head			"A" Round Washer Head			"B" Body Dia		"C" Thread Dia	
	Max"	Min"	Max"	Min"	T Max"	Max"	Min"	T Max"	Max"	Min"	Max"	Min"
4	0.225	0.195	0.219	0.205	0.086	N/A	N/A	N/A	0.095	0.084	0.116	0.105
6	0.279	0.244	0.270	0.256	0.103	N/A	N/A	N/A	0.118	0.107	0.142	0.131
8	0.332	0.292	0.322	0.306	0.120	0.376	0.352	0.110	0.136	0.125	0.168	0.157
10	0.385	0.340	0.373	0.357	0.137	0.443	0.411	0.125	0.157	0.146	0.194	0.183
12	0.438	0.389	0.425	0.407	0.153	N/A	N/A	N/A	0.176	0.165	0.220	0.209
14	0.507	0.452	0.492	0.473	0.175	N/A	N/A	N/A	0.201	0.190	0.246	0.235

Note: IFI Standards specify a tolerance on screw length of +0", -1/16".

Size	"A" Flat Head	"A" Pan Head	"A" Round Washer Head	"B" Body Dia	"C" Thread Dia
	Max Dia"	Max Dia"	T Max"	Max"	Max"
4	7/32	7/32	3/32	N/A	N/A
6	9/32	17/64	7/64	N/A	N/A
8	21/64	21/64	1/8	3/8	7/64
10	25/64	3/8	9/64	7/16	1/8
12	7/16	27/64	5/32	N/A	N/A
14	1/2	31/64	11/64	N/A	N/A